

## GLOW LOOP SCORCHER

### BEFORE YOU BEGIN ...

1. Unpack the parts. Save the packing materials.
2. Match the parts to the drawings below.
3. If you have each part, put a check in the box next to the picture of the part. Look in the carton again and check all of the packing materials to make sure you haven't missed anything.



### WARNING:

**CHOKING HAZARD - Small parts  
Not for children under 3 years.**

#### CHECK LIST

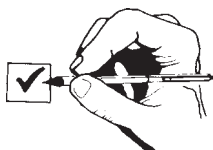

DARDA™ RACER (1)



LOOP HALVES (12)



14" STRAIGHT TRACK (2)



CVD. SUPPORT TRACK (4)



LARGE BASE PLATE (2)



STACKING BRIDGE (2)



TRACK JOINERS (4)



LOOP JOINERS (12)



### IF A PART IS MISSING OR DAMAGED ...

The store where you purchased this item does not have parts. You will get the easiest service from **Walthers**. Tell us the part(s) needed and be sure to include your name and address printed clearly. Mail to Wm. K. Walthers, Inc./ 5601 W. Florist Ave./Milwaukee, WI 53218/ Attn.: DARDA.

# READ ALL INSTRUCTIONS BEFORE YOU BUILD YOUR TRACK LAYOUT!!!

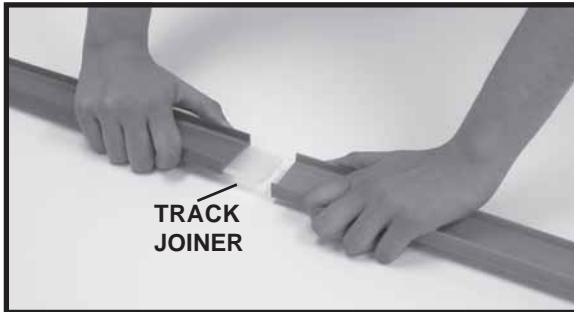

## USING TRACK JOINERS

Slide the Track Joiner - with the raised edges facing down - half way into the channel on the underside of the track piece. Now slide the adjoining track piece over the open half of the joiner, so that it meets the first piece. Be sure the tracks meet with no gaps.

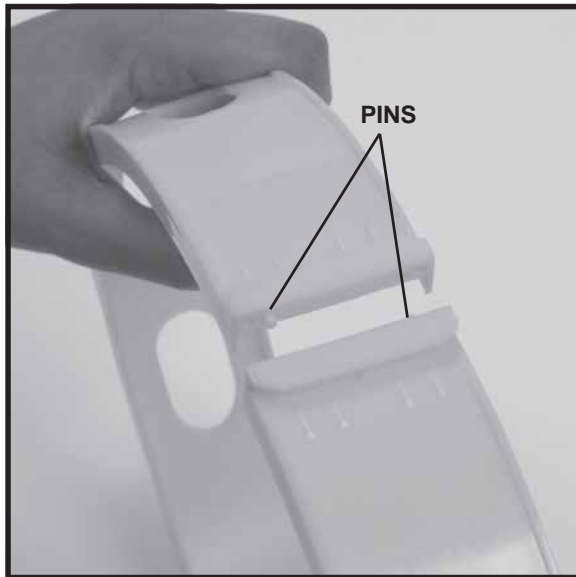

## MAKING LOOPS

Put two **LOOP HALVES** together so that the **PINS** at the top of each loop half go into the proper holes, creating a tight fitting seam between the two loop halves.

Holding the **LOOP HALVES** together, slide one **LOOP JOINER** over one end of the seam and the other loop joiner over the other end of the seam. Squeeze together to secure the joiners to the loop. **NOTE: Make the 6 loops in this set before building the track.**



FIGURE 1

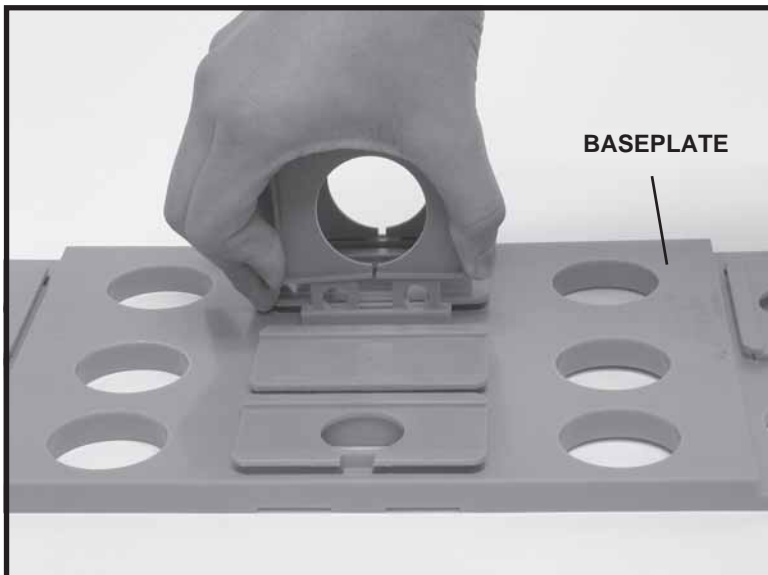

## STEP 1 • BUILD THE TRACK

Place **BRIDGE** on **BASEPLATE** by squeezing the bridge as shown in **FIGURE 1**. The **BRIDGE** will snap into place on the **BASEPLATE**. Repeat this step on second baseplate.

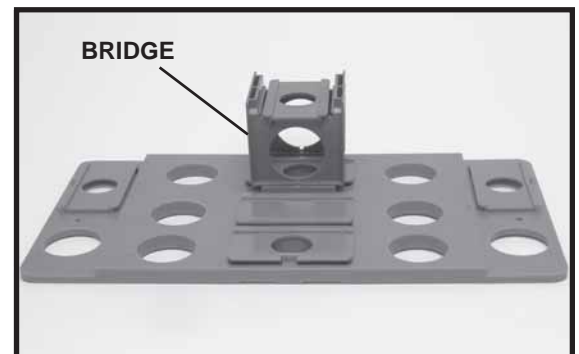
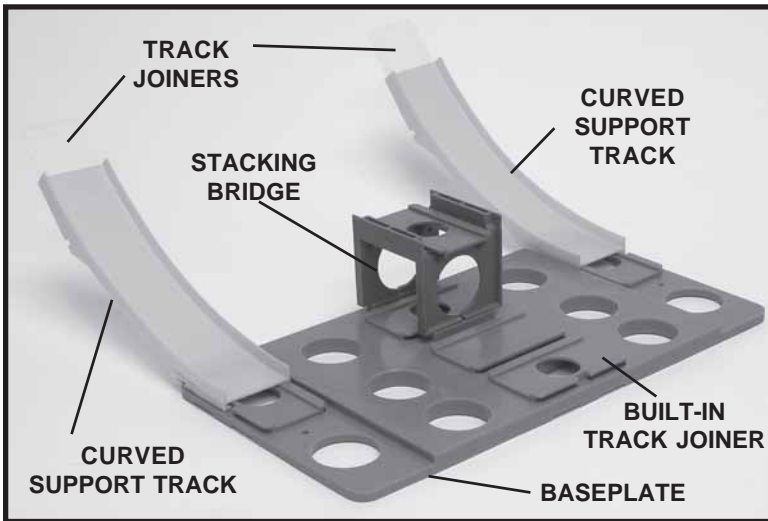

FIGURE 2



**STEP 2 • CONNECT SUPPORT TRACKS**

Connect the **CURVED SUPPORT TRACK** to the built-in track joiners on each end of the **BASEPLATE** by sliding the ends over half of the built-in track joiners. Add two track joiners to the other ends of the curved support track. Repeat this step on second baseplate

**STEP 3 • ATTACHING LOOPS**

Three loops will be used on each baseplate.

1. Connect **LOOP 1** to one of the **CURVED SUPPORT TRACKS** and the **BUILT-IN TRACK JOINER** on the baseplate as shown in **FIGURE 3A**.
2. Connect one end of **LOOP 2** to the **BASEPLATE** meeting up with Loop 1. The other end will slide on to the **STACKING BRIDGE** as shown in **FIGURE 3B**.
3. Connect **LOOP 3** to the **STACKING BRIDGE**, meeting up with Loop 2 and complete the circuit by connecting the other end of **LOOP 3** to the second **CURVED SUPPORT TRACK** **FIGURE 3C**. Repeat this step on the second baseplate.

FIGURE 3A

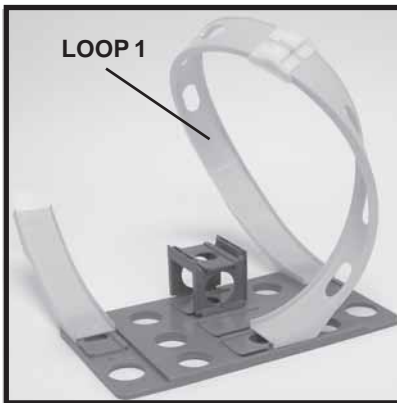

FIGURE 3B

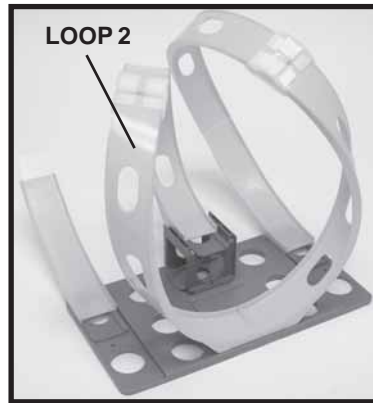
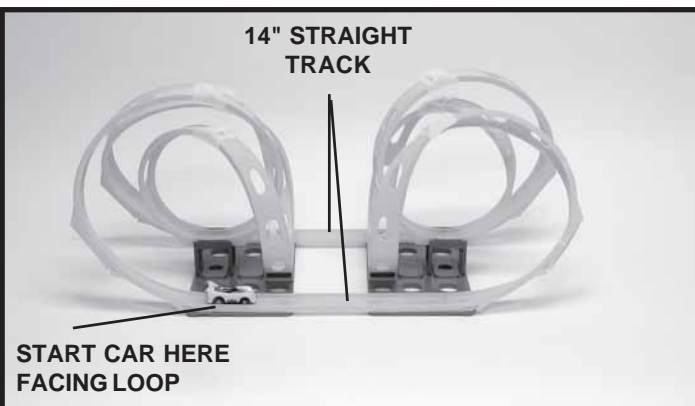
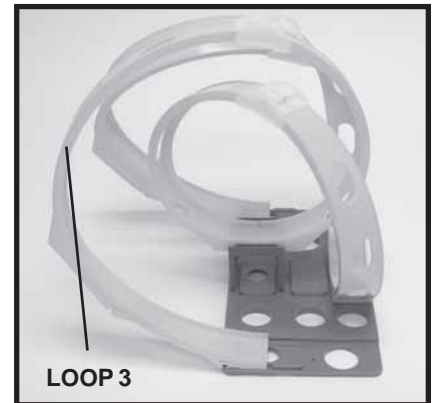

FIGURE 3C



**STEP 4 • SPEEDWAY TO FUN!**

Slide one 14" **STRAIGHT TRACK** onto the built-in track joiner to meet up to the **CURVED SUPPORT TRACK** on the **BASEPLATE**. Repeat on the other side of base plate. Now connect the Straight tracks to the second baseplate of loops and your set is complete!

# READY, SET, GO!!!

1. Press down on vehicle body until you hear a click.

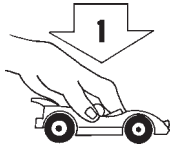

2. While still pressing down, roll vehicle back & forth until the clicking sound gets louder.

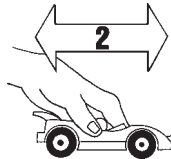

3. Lift your hand up off the vehicle while rolling forward. Watch it go!

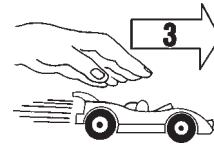

## Tips

- For consistent performance position your Darda™ Racers on the track layout as shown on page 3.
- Be sure that the vehicle is fully wound by listening for the click to get louder before releasing it.
- Have fun with your Darda™ vehicles on or off the Darda track. For longer life **DO NOT** run on carpet.
- Replacement motors are available at your local specialty toy store; or contact Darda at the number below.

## ALTERNATE LAYOUTS.

Darda™ track sets are very versatile, and you can build many track layouts from the parts. Here are 2 other raceways you can make with the parts in your **GLOW LOOP SCORCHER** set. After that...

## USE YOUR IMAGINATION!

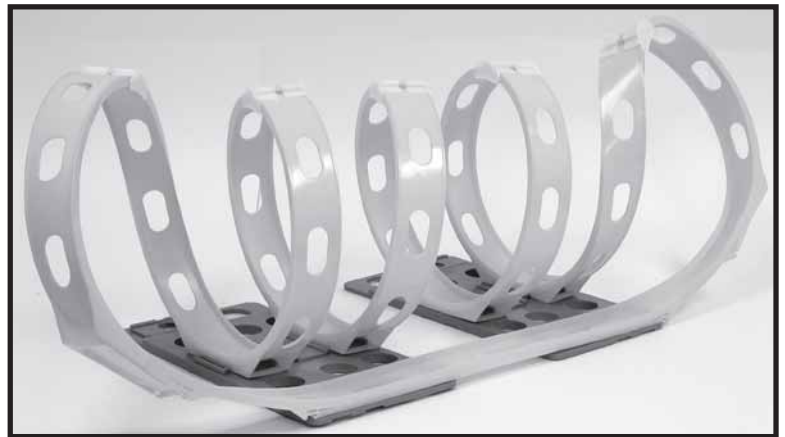

## TRACK TIPS

- Read all assembly instructions carefully.
- If your vehicle has trouble making it around the track, try the following: 1) Be sure that all track seams meet and connections are secure. Track pieces must meet flush against each other where they are connected with track and loop joiners, without gaps or bumps at the joint. 2) It may be necessary to play with, adjust, or slightly bend loops in track layouts to maximize performance. Remember Darda™ track is flexible.
- Darda™ track layouts can be set up on any flat surface. While it is not ideal, your track can be set up on carpet. We do recommend dusting off the track before use so that the dust particles from the carpet do not jam the motor. We do not recommend running the vehicle itself on carpet.
- Double check your assembly instructions, if you still have difficulty we want to help!

Call our toll free consumer hotline... 1-866-833-1468. (Mon.-Fri., 9:00am-3:30pm (Central Standard Time))